

TECHNICAL PRODUCT SHEET

MIRACELL®

RBC Wastewater Treatment System



System Overview

Miracell®, powered by Miranda Water Technologies, is a decentralized wastewater treatment solution based on Rotating Biological Contactor (RBC) technology, a fixed film biological process engineered to remove organic and nitrogen-based pollutants from wastewater.

Its core treatment mechanism uses closely spaced high-density polyethylene disks mounted on a solid horizontal shaft (C1050). As the disks rotate slowly while partially submerged (40%), a biofilm of aerobic microorganisms forms on their surfaces. These organisms metabolize organic matter by cycling between contact with wastewater and exposure to air, using atmospheric oxygen for biological treatment.

To accelerate startup and improve early performance, Miracell® is seeded during commissioning with a proprietary blend of aerobic microorganisms. This ensures rapid biofilm development and consistent system activation, even in environments with variable influent quality.

Continuous rotation provides passive aeration, eliminating the need for blowers and significantly reducing energy consumption. It also helps regulate biofilm thickness and maintains stable treatment performance under changing loads.

With a compact modular design, low power requirements, and minimal maintenance needs, Miracell® delivers a reliable and cost-effective solution for high quality wastewater treatment. It is especially well suited for applications prioritizing water reuse, energy efficiency, and decentralized infrastructure.



Key Features and Benefits



Energy Efficient

Naturally oxygenates wastewater through disk rotation, reducing energy use by up to 80% without mechanical aeration.



Low Maintenance

Self-regulating biofilm and automated operation reduce oversight and lower operational costs by up to 50%.



Reliable Performance

Maintains stable treatment efficiency under variable loads and conditions.



Modular and Scalable

Compact design fits tight sites and expands with 50 m³/day modules that can be serviced or added without downtime.



Low Footprint

Modular layout requires significantly less space than conventional systems.



Quick to Deploy

Preassembled with minimal site work, reducing installation time and complexity.



Easy to Transport

Skid-mounted units simplify delivery and setup, even in remote or challenging locations.



Quiet Operation

Runs below 48 decibels, ideal near homes, hotels, and other occupied buildings.



Odorless

Fully aerobic treatment removes unpleasant smells, suitable for populated or sensitive areas.



Sustainable Water Management

Produces high-quality effluent for reuse or discharge with minimal chemical use and sludge.



Corrosion Resistant Design

Glass-reinforced fiber and stainless steel 316 ensure durability and long-term corrosion resistance.



Minimal Excavation Required

Limits land disruption and protects vegetation by avoiding large-scale piping and earthworks.

Technical Specifications

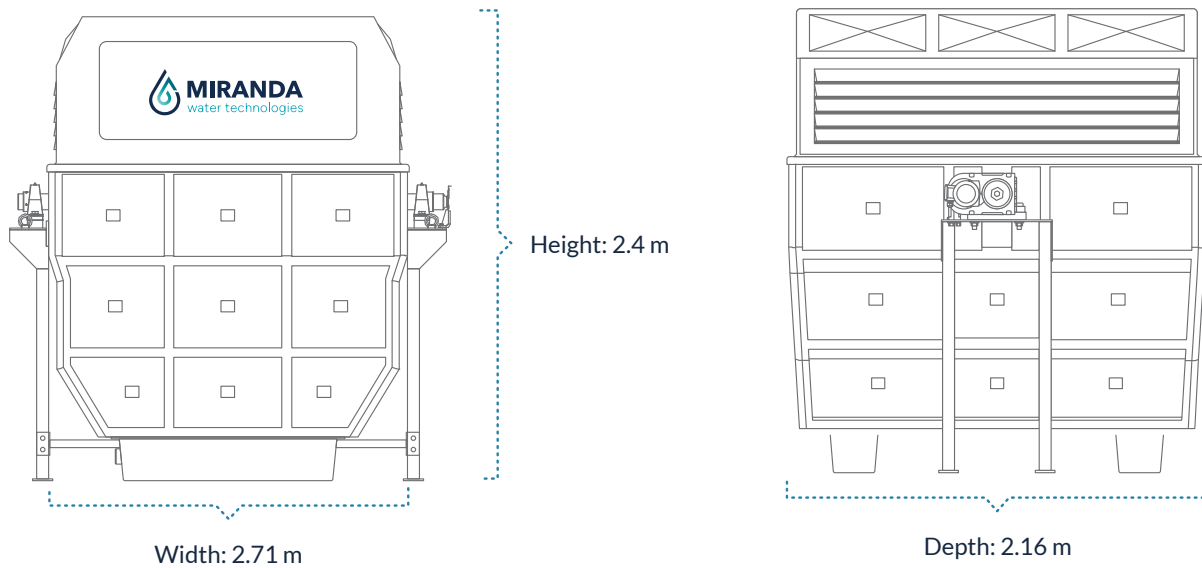

PARAMETER	SPECIFICATIONS PER MODULE (METRIC UNITS)
Treatment Capacity	50 m ³ /day
Power Consumption	0.37 kW
Energy Use	< 0.18 kWh/m ³ of treated water
Noise Level	< 48 dB
Disk Surface Area	466 m ² per unit
Materials	2 mm HDPE semicircular disks, 5–6 mm GRP body reinforced internally with stainless steel box profile, mounted on a stainless steel or hot-dip galvanized ST37 carbon steel outer frame.
Internal Volume	3.5 m ³
Tare Weight	750 kg
Gross Weight	4,250 kg
Installation	Skid-mounted, suitable for above or below grade
Operating Temperature	12°C to 32°C (typical)

Certifications & Compliance

- ISO 9001 Manufacturing Compliance
- Effluent meets discharge standards in North America, Europe and many other international jurisdictions

Miracell® Essential

Miracell® Module + Sedimentation Tank

- Low Energy Consumption
- Low Maintenance
- Modular & Scalable
- Corrosion-Free Composite (GRP)
- Minimum Consumables
- Standard Water Quality

Target Effluent Standards

BOD 45 COD 120 TSS 45



Miracell® Plus

Miracell® Essential + Sand Filter + Disinfection

- Low Energy Consumption
- Low Maintenance
- Modular & Scalable
- Corrosion-Free Composite (GRP)
- Minimum Consumables
- High Water Quality

Target Effluent Standards

BOD 25 COD 110 TSS 35

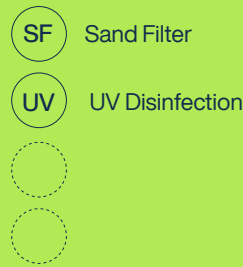

Miracell® Ultra

Miracell® Plus + Ultrafiltration

- Low Energy Consumption
- Low Maintenance
- Modular & Scalable
- Corrosion-Free Composite (GRP)
- Minimum Consumables
- Superior Water Quality

Target Effluent Standards

BOD ≤ 20 COD ≤ 50 TSS ≤ 10

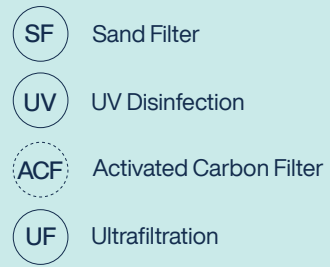

MIRACELL®

PROCESS FLOW DIAGRAM

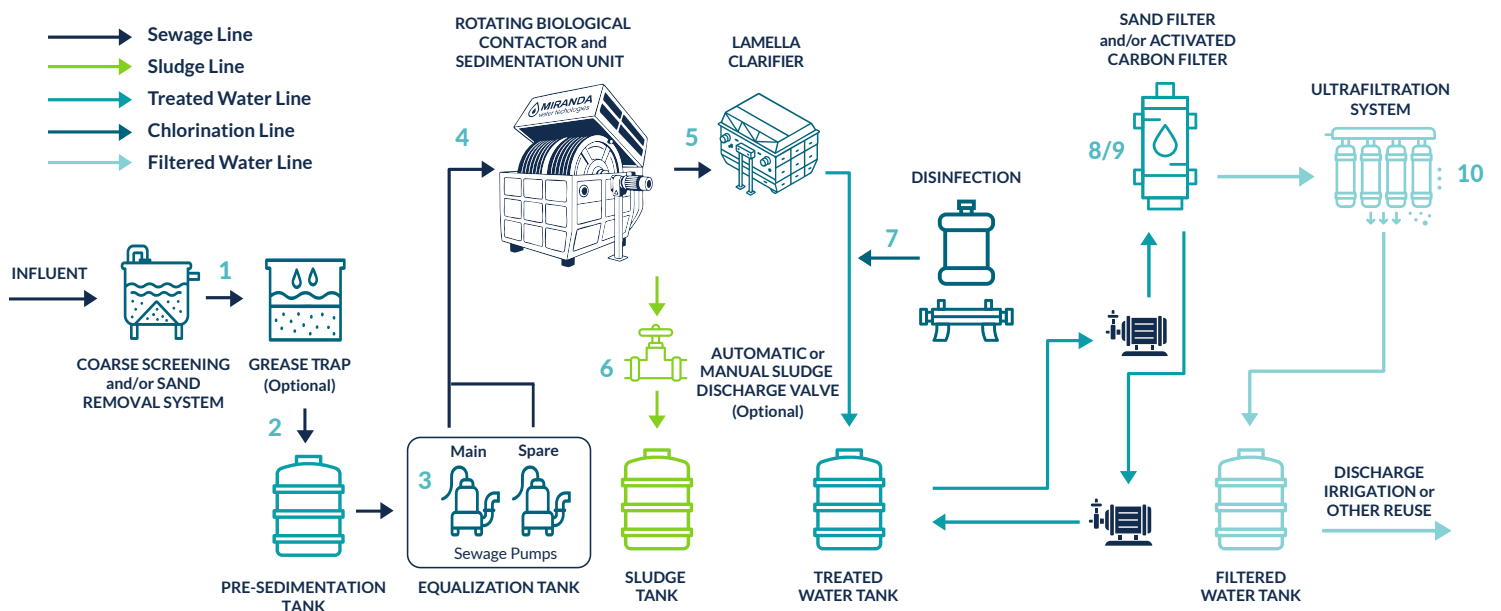

PHYSICAL TREATMENT

BIOLOGICAL TREATMENT

DISINFECTION SYSTEM

FILTRATION SYSTEM



STAGE	DESCRIPTION
1 Physical Screening	Begins with pretreatment to remove coarse materials that could damage or block downstream components.
2 Pre-Sedimentation Tank	Wastewater from the lifting station enters pre-sedimentation tanks with a T-type weir. These remove most suspended solids and some organic matter.
3 Equalization Tank	Clarified flow moves into the equalization tank, balancing volume and load fluctuations for consistent flow into biological treatment.
4 Biological Treatment (RBC Modules)	Wastewater is pumped into RBC Modules where rotating biodisks support aerobic biofilm growth to break down organic pollutants.
5 Lamella Clarifier	After biological treatment, flow passes through lamella separators that act as settlement tanks for fine solids.
6 Sludge Discharge Valve	Stabilized sludge is automatically discharged for about two minutes daily through a flush valve.
7 Disinfection (Chemical or UV)	Clarified water is disinfected using in-line chlorination, UV or ozone, then stored in a treated water tank.
8 Activated Carbon (Optional)	When chlorination is used, activated charcoal may be added post-treatment to remove residual chlorine.
9 Sand Filtration Unit (Optional – Miracell® Plus)	Treated water may pass through sand filters to remove suspended particles and improve clarity.
10 Ultrafiltration (Optional – Miracell® Ultra)	A final polishing step using ultrafiltration to produce ultra-clear, hygienic-quality water for reuse.
11 SmartCell Control System (Optional)	An integrated system monitors all treatment stages in real time, offering remote access, automated alerts, and data logging to support compliance and proactive management.



Discover how Miracell® delivers cost-effective, scalable, and sustainable wastewater treatment.

CONTACT US TO LEARN MORE

Miranda Water Technologies Canada

15 McCallum Place
Keene, ON K0L 2G0
Canada
Phone: +1-866-959-2837

Miranda Water Technologies Türkiye

Beyaz Zambaklar Sk. No: 34/2
PK 06700, Gaziosmanpaşa (GOP)
Ankara, Türkiye
Phone: +90 312 473 40 70

Miranda Water Technologies Türkiye (Manufacturing)

Batı Sitesi Mahallesi, Gersan Sanayi Sitesi
2307. Sokak No: 5
Türkiye
Phone: +90 312 385 72 52

Miranda Water Technologies Turks and Caicos Islands

3rd Floor, Salt Mills Plaza, Grace Bay
Providenciales, TKCA 1ZZ
Turks and Caicos Islands
Phone: +1 649 341 3689
Distributed by Been Construction Ltd

Rainmaker Worldwide Inc. United States

2510 East Sunset Road
Suite 5 #925
Las Vegas, NV 89120
United States
Phone: +1 702 608-1990

Rainmaker Mexico Mexico

Carretera a la Guayana Km 0.4 S/N
Colonia Medio Kilo
San Francisco de los Romo,
Aguascalientes 20350
Mexico
Phone: +52 492 544 4999



Copyright © 2025 Miranda Water Technologies. All rights reserved.

sales@mirandawater.com
mirandawater.com

